

Key Specifications

- Full featured Wi-Fi 6, 12 Stream AP
- 8x8:8 5GHz Radio + 4x4:4 2.4 GHz Radio
- Up to 1.1 Gbps data rate for 2.4 GHz radio
- Up to 9.6 Gbps data rate for 5 GHz radio
- Additional 2x2 dual band radio for dedicated RF and WIPS scanning
- Integrated omni directional antennas
- 20/40/80/160 MHz channel width support
- 2x 5 Gigabit Ethernet ports
- Support for UL/DL MU-MIMO
- Support for UL/DL OFDMA
- PoE++ support
- PoE+ support with reduced function
- Wall and ceiling mounting options
- Integrated BLE

Key Features

- Distributed Control Plane architecture and Flexible Data Plane
- Zero-touch deployment through automatic cloud activation and configuration
- Cloud or on premises management plane options
- Operating modes for dedicated access, dedicated security or dual-mode
- Support for up to 8 distinct SSIDs per radio
- Integrated firewall, traffic shaping, QoS and BYOD controls per SSID
- Dynamic RF optimization through smart steering, band steering and optimal channel selection
- Application visibility through layer 7 deep packet inspection
- Automated device access logging
- Patented Marker Packet™ technology for rogue AP detection and classification
- Wired VLAN monitoring for “No-WiFi” zone enforcement
- Third party analytics integration with real-time data transfer
- Versatile 3rd radio for WIPS, Scanning and Client Connectivity Tests
- Self-healing wireless mesh networking

Aesthetic Design and High Performance

Arista C-260 is an enterprise-grade, 12 stream Wi-Fi 6 AP with dual concurrent 5 GHz and 2.4 GHz band radios supporting 8 stream 802.11a/n/ac/ax, 4 stream 802.11b/g/n/ax and data rates of up to 4.8 Gbps and 1.4 Gbps, respectively. It also has a 2.4GHz Bluetooth Low Energy (BLE) radio.

C-260 Capabilities

C-260 provides Gen 2 Wi-Fi 6 performance improvements to deliver higher capacity and more efficient use of the available spectrum. It provides industry leading user experience and throughput in high density environments. Uplink/ Downlink OFDMA channelization allocates bandwidth more efficiently across client devices to provide a better user experience. The ability to serve multiple clients simultaneously through UL/DL MU-MIMO further improves system capacity and user experience. With support for eight spatial streams in 5GHz, the C-260 delivers truly unprecedented throughput and client capacity. C-260 is ideal for critical, high-density networks serving a high volume of diverse clients and applications. Common deployment scenarios include large schools, large remote offices, auditoriums, meeting rooms, and enterprise campuses.

Arista CloudVision® Managed Wi-Fi

The C-260 is an Arista CloudVision Wi-Fi managed platform. Available as a cloud service or on prem management platform, CloudVision Wi-Fi leverages a purpose built cloud architecture delivering cloud grade analytics and automation to enterprise Wi-Fi networks. CloudVision ensures high reliability, scalability, security and cost effectiveness.

Versatile, multipurpose 3rd Radio

C-260 comes with a versatile multipurpose 2x2:2 dual band 802.11ac third radio that provides:

- Industry leading, continuous WIPS
- Better RRM decisions from continuous spectral visibility
- Network availability and performance assurance by On-demand and scheduled client connectivity test



Arista C-260

Access

C-260 provides Wi-Fi networks that require less time and resources to deploy and maintain compared to traditional devices, resulting in significant cost savings.

- Plug and play provisioning using either Cloud or On-premise deployments - Arista Access Points take less than two minutes to activate and configure after connecting to the cloud
- Support for up to eight individual SSIDs per radio providing maximum flexibility in network design
- Network controls like NAT, Firewall and QoS implemented at the Access Point, ensuring faster and more reliable networks
- Continuous scanning of all 2.4 GHz and 5 GHz channels by a dedicated 2x2 third radio provides a dynamic, 360 degree view of the RF environment to assist in RF optimization and client handling
- Network availability and performance assurance using the third radio as a client to conduct on-demand and scheduled connectivity and performance tests
- Smart steering addresses sticky client issues by automatically pushing clients with low data rates to a better access point
- Band steering manages channel occupancy, pushing clients to the 5 GHz channel for optimal throughput
- Smart load balancing distributes load evenly across neighbouring APs to optimize the use of network resources
- Arista Wi-Fi's distributed control plane architecture continues to serve users and secure the network even if connection with the management plane is interrupted
- Interference avoidance from LTE/3G small/macro cells/CBRS in commonly used TDD/FDD frequency bands

Security

C-260 offers complete visibility and control of the wireless airspace ensuring network integrity while actively protecting users without manual intervention.

- C-260 is equipped with industry leading fully integrated wireless intrusion prevention capabilities
- Multifunction third radio provides uninterrupted spectrum scanning or client emulation for always on security coverage alongside dedicated 2.4G/5G client radios.
- Arista's patented Marker Packets™ help accurately detect rogue access points on any network while minimizing false positives
- Third radio used as a dedicated security sensor for 24x7x365 scanning and automated over-the-air (OTA) prevention
- Deterministic rogue AP detection and prevention by monitoring all WiFi and non-WiFi VLANs.
- Over-the-air and on-the-wire prevention techniques assure automatic and reliable threat prevention to keep unauthorized clients and rogue APs off the network without impacting authorized connections.
- Access Points autonomously scan for wireless threats and enforce security policy even if disconnected from the cloud management plane
- VLAN monitoring enables a virtual connection to non-WiFi networks for complete network rogue detection and prevention

Analytics

The C-260 collects telemetry on connected and unconnected WiFi clients and supports immersive guest network experiences that help Arista's customers develop and reinforce the relationship with their end customers.

- Reports of customer footfall, demographic, loyalty and other analytics provide insightful and actionable information.
- Supports proximity marketing programs that trigger when certain devices are present, which includes automatic messaging via MMS in-browser notifications and real time notifications sent to 3rd party systems that alert to the presence of enrolled devices.

	Property	Specification
	Physical Dimensions	230mm x 230mm x 45mm/9.1" X 9.1" X 1.77"
	Weight	1.390 Kg / 3 lb
	Operating Temperature	0°C ~ +40°C (+32°F ~ +104°F)
	Storage Temperature	-40°C ~ +70°C (-40°F ~ +158°F)
	MTBF	191,367 hr @ 40°C 333,286 hr @ 25°C
	Humidity	0-95% non-condensing
	Power Consumption	35.2 W (max) / 15.8 W (min) / 30.0 W (avg)
	Chipset	Qualcomm IPQ8078 2.2GHz quad core ARM processor with QCN5054 x2 and QCN5024 QCA9882 (multipurpose third radio)
	Processor and RAM	1 GB RAM and 512 MB Flash
	Physical Security	Kensington lock slot

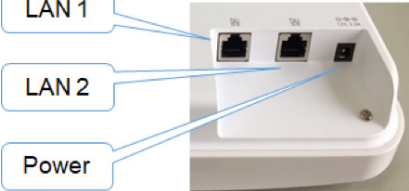
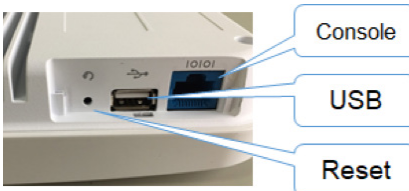
	Port	Description	Connector Type	Speed/Protocol
	Power	12V DC	5.5 mm overall diameter / 2.1 mm center pin hole	N/A
	LAN1	5 GbE, PoE++ compliant, MACsec capable*	RJ-45	100M/1G/2.5G/5G Ethernet Recommended cabling - CAT6
	LAN2	5 GbE, PoE++ compliant, MACsec capable*	RJ-45	100M/1G/2.5G/5G Ethernet Recommended cabling - CAT6
	Console	Establish 'config shell' terminal session via serial connection	RJ-45	<ul style="list-style-type: none"> RS 232 Serial (115200 bits per second) Data bits:8; Stop bits: 1 Parity: None Flow Control: None
	USB	USB 2.0 port	USB Type-A	<ul style="list-style-type: none"> Future use
	Reset	USB 2.0 Reset to factory default settings port	Pin hole push button	Let the AP boot up fully, ensure that all the LEDs are ON. Press the reset button for 15 seconds.

* MACsec capabilities will be activated via a future software update.

Operational Specifications

Input Power	12V DC (5.5mm overall diameter/2.1mm center pin hole) PoE++ power <ul style="list-style-type: none"> • Full function • Hitless PoE failover between the two ethernet ports PoE+ <ul style="list-style-type: none"> • USB off • Max EIRP¹ of 28.5 dBm at 5 GHz, 25.5 dBm at 2.4GHz
Number of Radios	2 access radios; one 4x4:4 2.4GHz and one 8x8:8 5GHz radio for simultaneous dual band access. 1 multi-function 2x2 radio for continuous WIPS and client connectivity tests
Max Clients Supported	768 (256 clients on 2.4 GHz radio, 512 clients on 5 GHz radio)
MU-MIMO	8X8 on 5GHz radio and 4X4 on 2.4GHz radio
Number of Spatial Streams	8 for 5GHz radios, 4 for 2.4 GHz radio, 2 for multipurpose radio
Maximum EIRP	32.5dBm on 5GHz radio (max) and 28.5dBm on 2.4GHz radio (max) ¹
80+80MHz Non-Contiguous Channel Bonding	No
Bandwidth Agility	Yes
Small Cells Interference Mitigation (pico-cells, femtocells, microcells)	Yes
Frequency Bands	2.4-2.4835 GHz, 4.9-5.0GHz, 5.15-5.25 GHz; (UNII-1), 5.25-5.35 GHz, 5.47-5.6 GHz, 5.650-5.725 GHz (UNII-2), 5.725-5.85 GHz (UNII-3)
Dynamic Frequency Selection	Supported in compliance to all latest amendments from FCC, CE, IC, CB, TELEC, KCC regarding certifications.

¹ Max EIRP will be restricted to Country/Regulatory domain limits

² The frequency ranges are restricted to Country/Regulatory domain limits

WiFi Specifications

IEEE 802.11a/n/ac/ax			
	Scanning	Transmission	
	All regions	USA & Canada (FCC/IC)	Europe (ETSI)
5GHz Band	4.92 ~ 5.08 GHz 5.15 ~ 5.25 GHz 5.25 ~ 5.35 GHz 5.47~ 5.725 GHz 5.725~ 5.825 GHz	5.15 ~ 5.25 GHz 5.25 ~ 5.35 GHz 5.725~ 5.825 GHz	5.15 ~ 5.25 GHz 5.25 ~ 5.35 GHz 5.47~ 5.725 GHz
Dynamic Frequency Selection	DFS and DFS2		
Modulation Type	OFDM / OFDMA		
Peak Data Rates	Up to 9.6 Gbps		
Antenna	Integrated modular high efficiency PIFA antenna x8 (peak gain: 6.1 dBi)		

IEEE 802.11b/g/n/ax			
Frequency Band	Scanning	Transmission	
	All regions	USA & Canada (FCC/IC)	Europe (ETSI)
2.4 GHz Band	2400 ~ 2483.5 MHz	2400 ~ 2473.5 MHz	2400 ~ 2483.5 MHz
Modulation Type	DSSS / OFDM / OFDMA		
Peak Data Rates	Up to 1.1Gbps		
Antenna	Integrated modular high efficiency PIFA antenna x4 (peak gain:4.92 dBi)		

Receive Sensitivity

5 GHz

Mode	Rate	Sensitivity (dBm)
802.11a	6 Mbps	-92
	54 MBps	-75
11n_HT20	MCS 0	-93
	MCS 7	-75
11n_HT40	MCS 0	-90
	MCS 7	-73
11ac_VHT20	MCS 0	-95
	MCS 8	-70
11ac_VHT40	MCS 0	-90
	MCS 9	-68
11ac_VHT80	MCS 0	-87
	MCS 9	-63
11ax_HE20	MCS 0	-93
	MCS 11	-64
11ax_HE40	MCS 0	-91
	MCS 11	-62
11ax_HE80	MCS 0	-87
	MCS 11	-59

2.4 GHz

Mode	Rate	Sensitivity (dBm)
802.11b	1 Mbps	-98
	11 MBps	-90
802.11g	6 Mbps	-93
	54 MBps	-77
11n_HT20	MCS 0	-95
	MCS 7	-76
11n_HT40	MCS 0	-91
	MCS 7	-73
11ac_VHT20	MCS 0	-95
	MCS 8	-72
11ac_VHT40	MCS 0	-91
	MCS 9	-70
11ax_HE20	MCS 0	-94
	MCS 11	-65
11ax_HE40	MCS 0	-91
	MCS 11	-63

Maximum EIRP

5 GHz

Mode	Rate	Power (dBm)
802.11a	6 ~ 18 Mbps	32.5
	24 ~ 54 Mbps	31.5
802.11n_HT20	MCS 0 ~ 4	32.5
	MCS 5 ~ 7	31.5
802.11n_VHT40	MCS 0 ~ 4	32.5
	MCS 5 ~ 7	30.5
802.11ac_VHT20	MCS 0 ~ 4	32.5
	MCS 5 ~ 7	31.5
	MCS 8 ~ 9	30.5
802.11ac_VHT40	MCS 0 ~ 4	32.5
	MCS 5 ~ 7	30.5
	MCS 8 ~ 9	29.5
802.11ac_HT80	MCS 0 ~ 4	32.5
	MCS 5 ~ 7	29.5
	MCS 8 ~ 9	28.5
802.11ax_HE20	MCS 0 ~ 4	32.5
	MCS 5 ~ 7	31.5
	MCS 8 ~ 9	30.5
	MCS 10- 11	27.5
802.11ax_HE40	MCS 0 ~ 4	32.5
	MCS 5 ~ 7	30.5
	MCS 8 ~ 9	29.5
	MCS 10- 11	27.5
802.11ax_HE80	MCS 0 ~ 4	32.5
	MCS 5 ~ 7	29.5
	MCS 8 ~ 9	28.5
	MCS 10 ~ 11	25.5

2.4 GHz

Mode	Rate	Power (dBm)
802.11b	1 ~ 11 Mbps	28.5
802.11g	6 ~ 18 Mbps	28.5
	24 ~ 54 Mbps	26.5
802.11n_HT20	MCS 0 ~ 4	28.5
	MCS 5 ~ 7	26.5
802.11n_HT40	MCS 0 ~ 4	27.5
	MCS 5 ~ 7	25.5
802.11ax_HE20	MCS 0 ~ 4	28.5
	MCS 5 ~ 7	26.5
	MCS 8 ~ 9	25.5
	MCS 10 ~ 11	21.5
802.11ax_HE40	MCS 0 ~ 4	27.5
	MCS 5 ~ 7	25.5
	MCS 8 ~ 9	25.5
	MCS 10 ~ 11	22.5

Radiation Patterns

2.4 GHz - Peak Gain: 4.92dBi

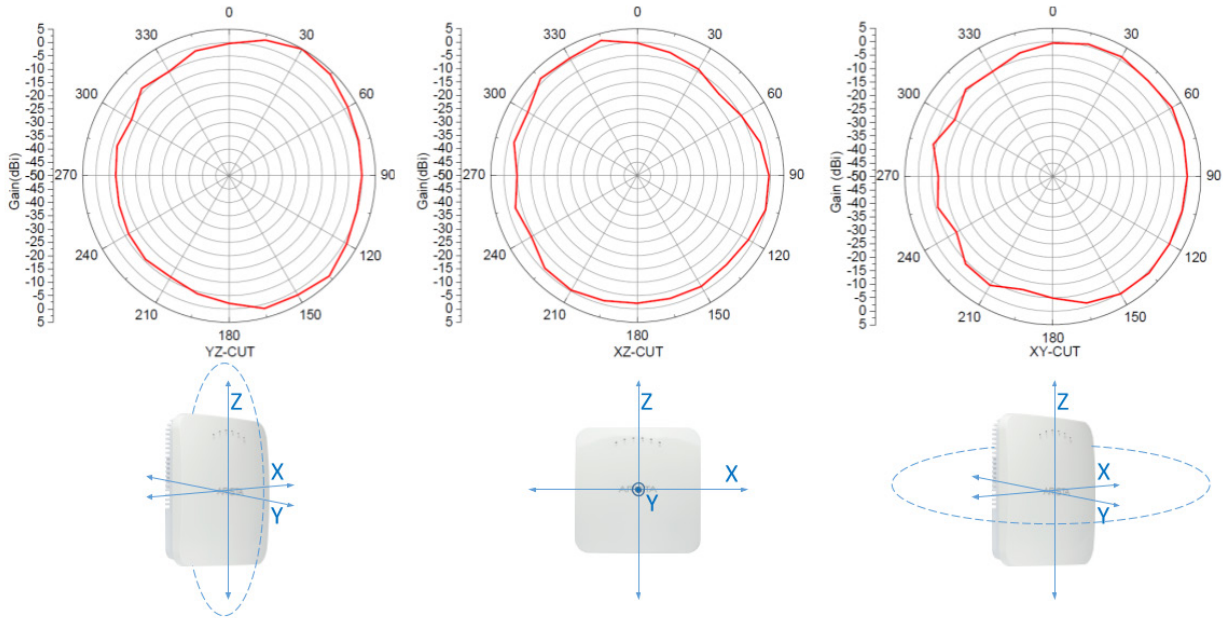

5 GHz - Peak Gain: 6.1dBi

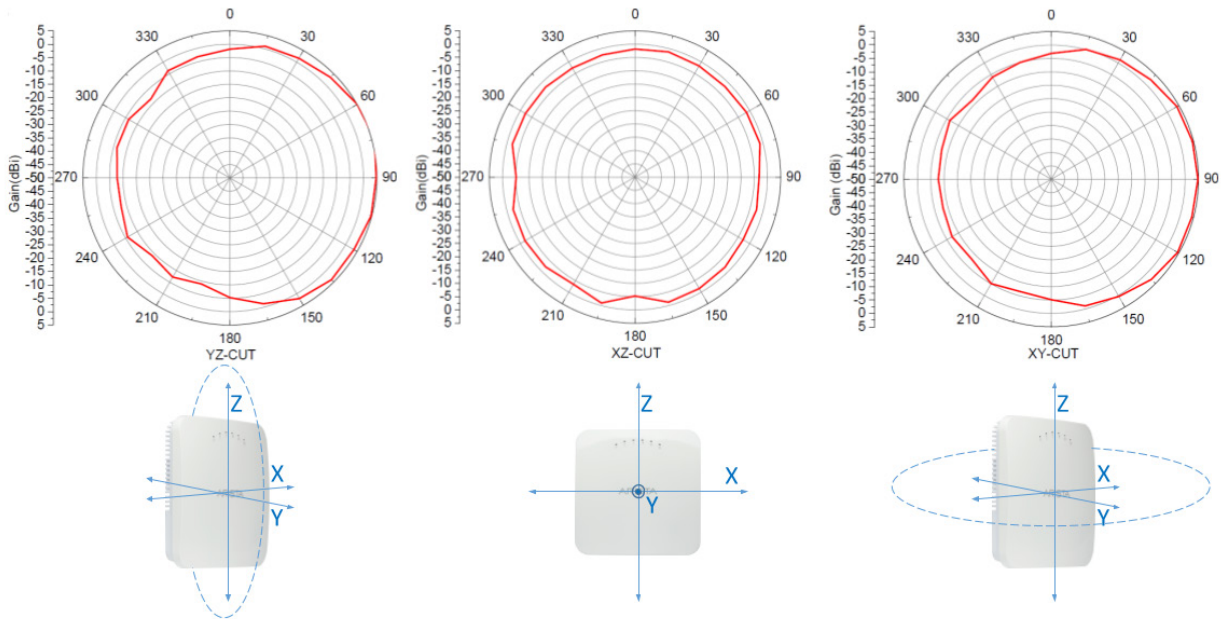

Regulatory Specifications RF and Electromagnetic Compatibility (EMC)

Country	Certification
USA	FCC Part 15.247, 15.407, 15B
Canada	ICES-003, RSS-247, RSS-102
Europe	CE EN 300 328, EN 301 893, EN 301 489 , EN 55032, EN 55024, EN 18031-1:2024 Countries covered under Europe certification: Austria, Belgium, Bulgaria, Croatia, Cyprus, Czechia, Denmark, Estonia, Finland, France, Germany, Greece, Hungary, Ireland, Italy, Latvia, Lithuania, Luxembourg, Malta, the Netherlands, Poland, Portugal, Romania, Slovakia, Slovenia, Spain, Sweden, United Kingdom.

*For complete country certification records, please visit the site: <https://www.arista.com/en/support/product-certificate>

Safety & Environmental

Country	Certification
USA, Canada	UL/cUL 60950, UL/cUL 62368, UL 2043
European Union (EU)	EN 60950, EN 62368 RoHS
China	GB/T 26125 RoHS
Taiwan	CNS 14336, CNS 15663 RoHS

Ordering Information Access Point

Part Number	Description
AP-C260	C-260 8x8 tri radio 802.11ax (WiFi 6) access point with internal antennas
AP-C260-SS-5Y	C-260 AP with 5 years bundled Cognitive Cloud SW subscription
AP-C260-SS-3Y	C-260 AP with 3 years bundled Cognitive Cloud SW subscription

Mounting Options

For details of mounting options, see the Access Points [Mounting Brackets Guide](#)

Power Supply

Part Number	Description
PWR-AP-W4	Universal AC power supply for C-230, 12VDC, 3.3A

Headquarters

5453 Great America Parkway
Santa Clara, California 95054
408-547-5500

Support

support@arista.com
408-547-5502
866-476-0000

Sales

sales@arista.com
408-547-5501
866-497-0000